

KEM-6NRW

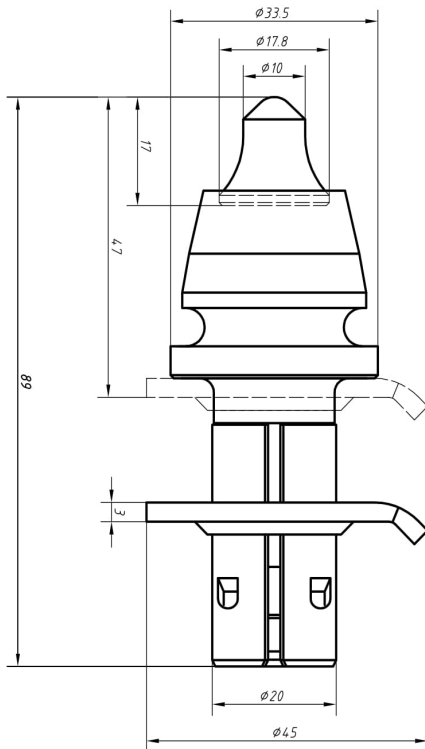

KEYSTONE	KEM-6NRW
Carbide Tip Base Diameter	18mm
Carbide Tip Length	17mm
Tool Height	89.2mm
Carbide Tip Weight	29.8gm
Carbide Density	14.93 gm/cm ³
Carbide Weight %	94%
Cobalt Weight %	6%
Hardness	87.5HRA
Washer Style	Non-Rotating

Application: Asphalt

Machine Category: Compact – Large Class Milling

- Patented non-rotating washer used to prevent block/holder face wear
- Universal cutting tool that can be used on all OEM drum systems
- Extended retainer for even block/holder wear
- Puller groove
- 50 tools per box/ 2,400 pallet