

HORIZONTAL FLOOR GRINDING

REPLACEMENT SYSTEMS FOR ALL GRINDING MACHINES

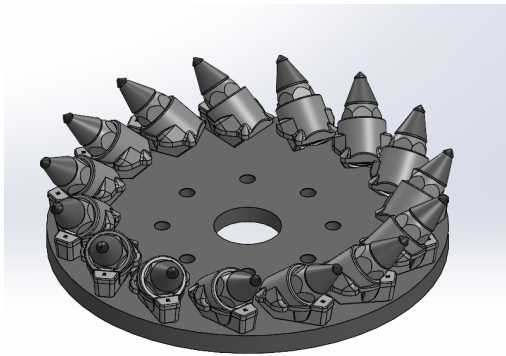

Rotary Plate with PCD Diamond Tools

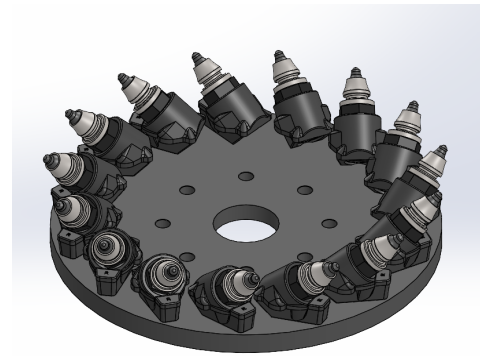

Rotary Plate with Standard Carbide Tools

Easy Screw Quick-Change System

- Interchangeable insert allows operators to easily change from carbide tools to diamond tools
- Decrease downtime by eliminating the need for in-field welding
- Increase production while leaving a smoother and cleaner surface pattern
- Replace inserts easily, unscrew insert with standard tools, no special tools required
- Taper on taper design ensures consistent insert locking depth, providing a smooth and uniform surface pattern

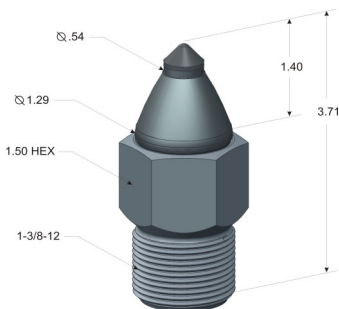

D-540 Diamond

D-540 PCD Diamond Tool

- Improve productivity by extending tool life by 40X
- Increase cutting efficiency
- Carbide bolster extends the life of the diamond
- Creates a smoother surface pattern

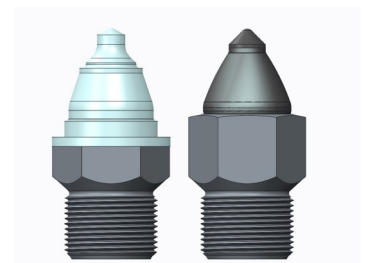

Carbide Tool

D-540 Tool