

D-540 Diamond Tool

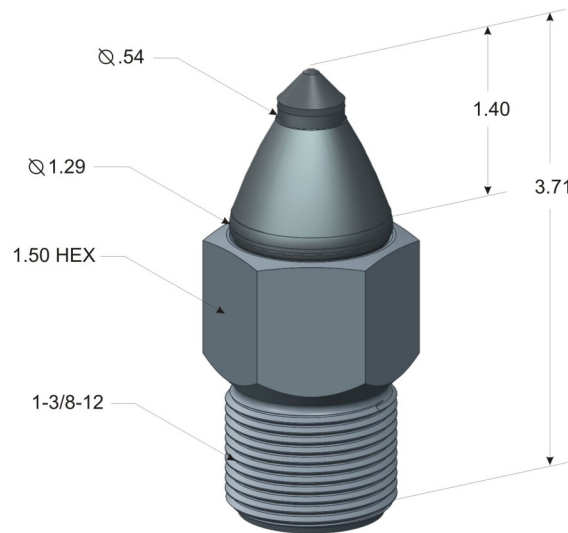

Keystone Engineering's D-540 PCD tool can easily be adapted to any quick-change grinding system. Interchangeable insert allows contractors to easily change from carbide tools to diamond tools.

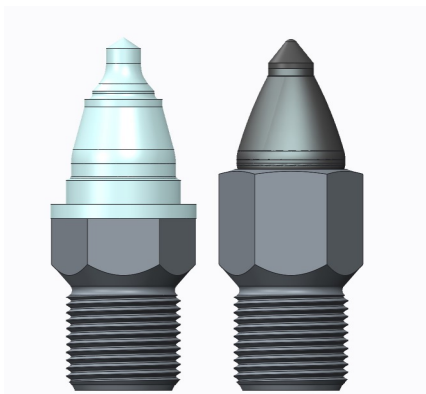

Standard Carbide Tool

D-540 Diamond Tool

- Improve productivity by extending tool life by 40X
- Reduce fuel consumption by increasing cutting efficiency
- Reduce overall maintenance cost of the machine by significantly reducing vibration
- Carbide bolster extends the life of the diamond
- Creates a smoother and more uniform surface pattern
- Improve employee work environment by requiring fewer tool changes and minimizing machine vibration