

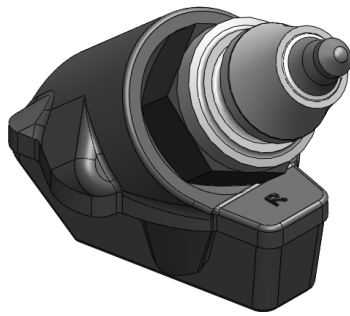

### EASY SCREW QUICK-CHANGE SYSTEM

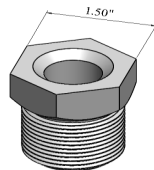

- Easy bit removal with access to the bit from the back of the block
- Easy holder removal-unscrew holder with standard tools, no hydraulic presses or special tools required
- Taper on taper design provides a consistent holder locking depth, providing a consistently smooth milled surface pattern



Easy Screw Insert

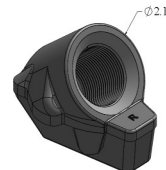

Easy Screw Base