

### ONE LOCK QUICK-CHANGE SYSTEM

- Interchangeable holders convert the drum's spacing to 5mm/7.5mm/15mm to meet any milling, fine milling or micro milling specification
- The replaceable bit holders are not tapered, reducing the locking force and making the holders easy to change out
- Only one bit holder used throughout the drum, eliminating the need to stock multiple holders
- The only drum system on the market that is designed to last the life of the machine—No costly rebuilds required
- Custom tailor the drum's spacing to increase or decrease gradation of the milled material on a job to job basis
- Change bits faster with easy access to the bit from the back of the holder

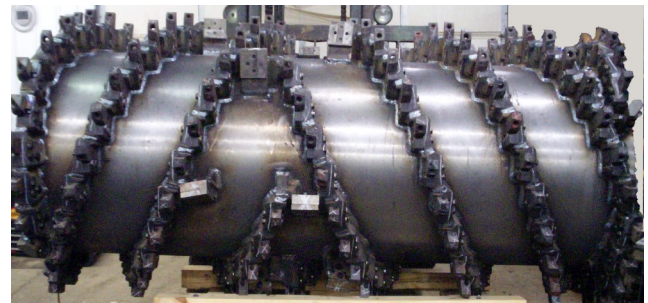

15mm spacing

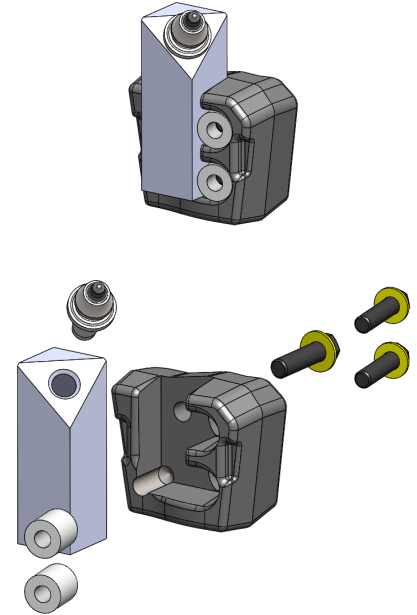
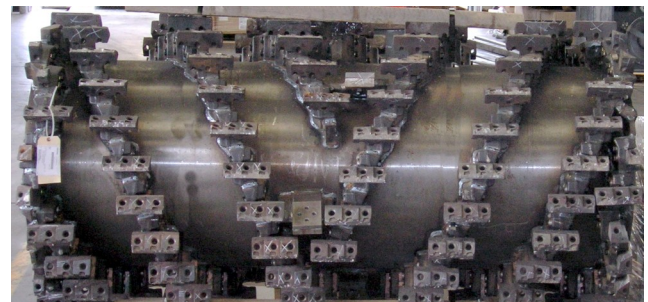

5mm spacing

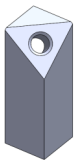

One Lock Holder—  
15 mm spacing

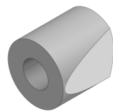

Wedge

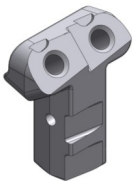

Double Hit One Lock Holder—  
7.5mm spacing



Wedge Bolt

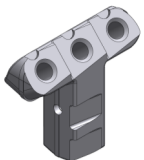

Triple Hit One Lock Holder—  
15mm spacing