

### KEM-7NRW

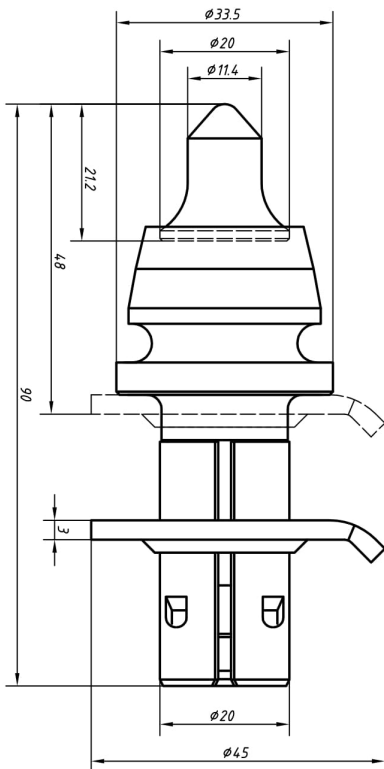

KEYSTONE	KEM-7NRW
Carbide Tip Base Diameter	20 mm
Carbide Tip Length	21.2 mm
Tool Height	89 mm
Carbide Tip Weight	38.6 gm
Carbide Density	14.93 gm/cm3
Carbide Weight %	94%
Cobalt Weight %	6%
Hardness	87.5 HRA
Washer Style	Non-Rotating

**Application:** Asphalt  
**Machine Category:** Large Class Milling

- Patented non-rotating washer used to prevent block/holder face wear
- Universal cutting tool that can be used on all OEM drum systems
- Extended retainer for even block/holder wear
- Puller groove
- Extended sleeve
- 50 tools per box/ 2,400 pallet